

TASCAM

TEAC Professional Division

SERVICE MANUAL

322

Double Auto Reverse Cassette Deck

CONTENTS

1. SPECIFICATIONS	2
2. ADJUSTMENT AND CHECKS	4
3. BLOCK DIAGRAM	11
4. EXPLODED VIEWS AND PARTS LIST	13
5. PC BOARDS AND PARTS LIST	18
6. INCLUDED ACCESSORIES	24

目次

1. 仕様	2
2. 調整と確認	4
3. ブロックダイアグラム	11
4. 分解図とパーツリスト	13
5. 基板図とパーツリスト	18
6. 付属品	24

INSTRUCTIONS FOR SERVICE PERSONNEL

BEFORE RETURNING APPLIANCE TO THE CUSTOMER, MAKE LEAKAGE-CURRENT OR RESISTANCE MEASUREMENTS TO DETERMINE THAT EXPOSED PARTS ARE ACCEPTABLY INSULATED FROM THE SUPPLY CIRCUIT.

1. SPECIFICATIONS

仕様

Tape : Compact cassette tape C-30/60/90
(Normal/High Position/Metal)
Track Format : 4-track, 2-channel
Head Configuration : 4-track, 2-channel ;
Record/repro combination rotary head
(DECK 1 x1, DECK 2 x1, permally)
Erase head (DECK 1 x1, DECK 2 x1, ferrite)
Motor : DC servo capstan motor (DECK 1 x1, DECK 2 x1)
DC reel motor (DECK 1 x1, DECK 2 x1)
Tape Speed : 4.76 cm/sec (1.87 ips) or 9.5 cm/sec (3.74 ips) at
HIGH SPEED dubbing
Pitch Control : approx. +/- 10 %

Line Input - RCA jack :
Nominal Input Level : -10 dBV (0.3V)
Minimum Input Level : -18 dBV (0.1V)
Input Impedance : 24k ohms
Line Output - RCA jack :
Nominal Output Level : -5 dBV (0.6V)
Output Impedance : 1.5k ohms
Cascade Output - RCA jack :
Nominal Output Level : -10 dBV (0.3V)
Output Impedance : 100 ohms
Headphone Output - 1/4" jack :
Output Power : 7 mW max./32 ohms

Bias/Erase Frequency : 100 kHz
Repro Equalization :
3180 μ s + 70 μ s (High Position/Metal)
3180 μ s + 120 μ s (Normal)
Reference Record Level : 250 nWb/m = 0 VU (315 Hz) (JEITA)
EXT CONTROL : 3.5 mm mini jack
REMOTE IN (FROM RC-322A) : 2.5 mm mini-mini jack
REMOTE IN (SERIAL) : RC-232C
Power Requirements :
USA/Canada/General Export Model :
120/230 V AC (50-60 Hz), switchable
U.K./Europe : 230 V AC (50 Hz)
Australia : 240 V AC (50 Hz)
Consumption : 33 Watts
Weight : 7.8 kg (17.19 lbs)

Typical Performance

Speed Accuracy : Less than +/-3.0%
Wow and Flutter : Less than 0.15% WRMS
Fast Winding Time : 120 sec. (approx.) with C-60 cassette
Frequency Response, Overall (JEITA, without NR) :
63 Hz to 18 kHz, +/-3 dB (Metal)
63 Hz to 16 kHz, +/- 3 dB (High Position)
63 Hz to 16 kHz, +/-3 dB (Normal)
Distortion : Less than 2.5%, at 1kHz, 160 nWb/m (Metal)

使用テープ : C - 30 ~ C - 90カセットテープ
(Normal, High Position, Metal)
トラック形式 : 4トラック、2チャンネル
ヘッド構成 :
録音再生ロータリーヘッド : (DECK 1 X 1, DECK 2 X 1)
(パーマロイ)
消去ヘッド : (DECK 1 X 1, DECK 2 X 1)
(フェライト)
モーター構成 :
キャプスタンモーター : DCサーボモーター
(DECK 1 X 1, DECK 2 X 1)
リールモーター : DCモーター (DECK 1 X 1, DECK 2 X 1)
テープ速度 : 4.8 cm/sec., 9.5 cm/sec. (ハイスピードダビング時)
ピッチコントロール : 土約 10%

ライン入力 : RCAピンジャック
規定入力レベル : -10 dBV (0.3V)
最小入力レベル : -18 dBV (0.1V)
入力インピーダンス : 24 k Ω
ライン出力 : RCAピンジャック
規定出力レベル : -5 dBV (0.6V)
出力インピーダンス : 1.5 k Ω
カスケード出力 : RCAピンジャック
規定出力レベル : -10 dBV (0.3V)
出力インピーダンス : 10 Ω
ヘッドホン出力 : ϕ 6.3 mmホンジャック
最大出力 : 最大7 mW / 32 Ω 負荷

バイアスおよび消去周波数 : 100 kHz
再生イコライザー :
ハーフ自動検出
3,180 μ s + 70 μ s (High Position, Metal)
3,180 μ s + 120 μ s (Normal)
基準録音レベル : 250 nWb/m = 0 VU (315Hz) (JEITA)
EXT CONTROL 端子 : ϕ 3.5 mmミニジャック
REMOTE IN (FROM RC - 322A) 端子 :
 ϕ 2.5 mmミニミニジャック
REMOTE IN (SERIAL) 端子 : RS - 232C
電源 : 100 VAC, 50 - 60 Hz
消費電力 : 33 W
質量 : 7.8 kg

定格

テープ速度偏差 : 土3.0%
ワウフラッター : 0.15%以内 (JIS WRMS)
早巻き時間 : 約 120 秒以内 (C - 60 使用時)
総合周波数特性 :
63 Hz ~ 18 kHz \pm 3 dB JEITA (Metal)
63 Hz ~ 16 kHz \pm 3 dB JEITA (High Position)
63 Hz ~ 16 kHz \pm 3 dB JEITA (Normal)
歪率 : 2.5%以下 1 kHz 160nWb/m (Metal)

Signal-to-Noise Ratio :

59 dB (without NR, ref. 3% THD, WTD) (Metal)
 69 dB (with Dolby-B NR, CCIR ARM) Noise level
 79 dB (with Dolby-C NR, CCIR ARM) Noise level

Channel Separation : Better than 30 dB (at 1 kHz)

Erase Ratio : Better than 65 dB (at 1 kHz)

Applicable Electromagnetic Environment : E4

Peak Inrush Current : 1.2 A

Accessories

Remote control unit (RC-322A) x 1

Rack mounting screw kit x 1

- In these specifications, 0 dBV is referenced to 1 volt. Actual voltage levels are shown in parenthesis.
- Improvements may result in specifications or feature changes without notice.

Dolby noise reduction and HX Pro headroom extension manufactured under license from Dolby Laboratories Licensing Corporation. HX Pro originated by Bang & Olufsen.

“DOLBY”, the double-D symbol  and “HX PRO” are trademarks of Dolby Laboratories Licensing Corporation.

SN 比 :

59 dB (NR Out 3% THD レベル WTD) (Metal)
 69 dB (Dolby B NR In CCIR ARM) ノイズレベル
 79 dB (Dolby C NR In CCIR ARM) ノイズレベル

チャンネルセパレーション : 30 dB 以上 (1 kHz)

消去率 : 65 dB 以上 (1 kHz)

付属品

RC - 322A リモコン (5m)

ラックマウントビスキット (ネジ M5 × 4、ワッシャー × 4)

* この仕様は、0 dBV=1V で表示しています。実際の電圧は () で示しています。

* 仕様および外観は、改善のため予告なく変更することがあります。

ドルビーノイズリダクション及びHXプロヘッドルームエクステンションはドルビーラボラトリーズライセンスコーポレーションからの実施権に基づき製造されています。HXプロはバングアンドオルフセンの考案です。

「ドルビー」、[DOLBY]、ダブルD記号  及び「HX PRO」はドルビーラボラトリーズライセンスコーポレーションの登録商標です。

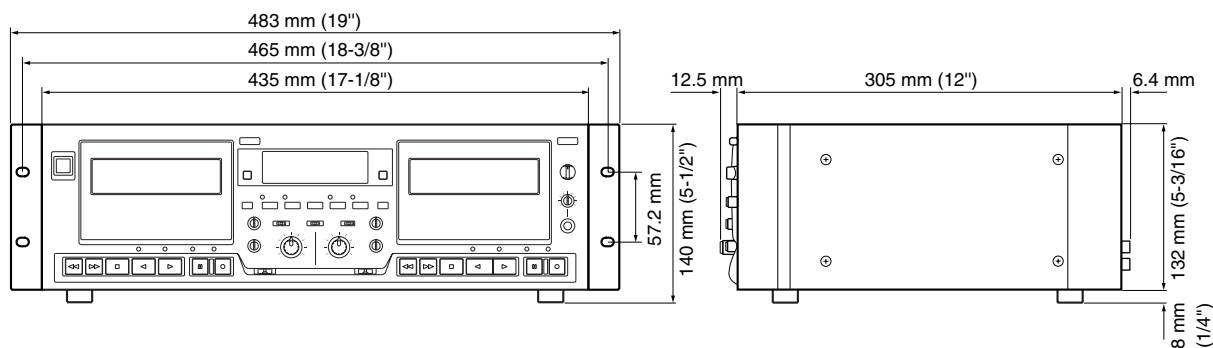
Dimensional Drawings 寸法図

2. ADJUSTMENT AND CHECKS

調整と確認

2-1. Mechanical Adjustment And Checks

2-1. 機構部の調整と確認

2-1-1. Wow and flutter

2-1-1. ワウフラッタ

1. Connect a wow-and-flutter meter to the deck as shown in Fig. 2-1.
2. Load and play a MTT-111N test tape.
3. Check that the readings on the wow-and-flutter meter is within 0.15 % (WRMS).

1. Fig. 2-1 のようにワウフラッタメーターを接続する。
2. テストテープ MTT-111N を再生する。
3. ワウフラッタ値が0.15 % (WRMS) 以内であること。

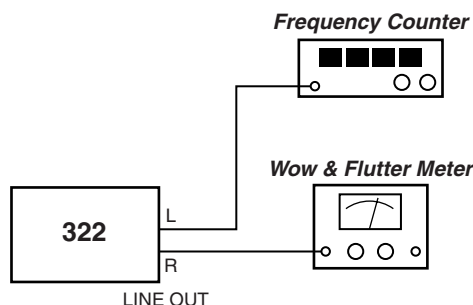

Fig. 2-1

2-1-2. Tape speed

2-1-2. テープ速度

1. Connect a frequency counter to the deck as shown in Fig. 2-1.
2. Load a MTT-111N test tape and play in FWD direction the beginning of the test tape.
3. Adjust each variable resistor on the MAIN PCB (Fig.2-2) to get the following figures.

1. Fig. 2-1 のように周波数カウンターを接続する。
2. テストテープ MTT-111N の巻き始め部を FWD 方向で再生する。
3. 周波数値が下表の範囲内になるように MAIN PCB の各調整 VR (Fig. 2-2) を調整する。

	ADJUSTMENT VR 調整 VR		ADJUSTMENT VALUE 調整値
DECK 1	HIGH speed	R51	6000 ~ 6020 Hz
	NORMAL speed	R52	3000 ~ 3010 Hz
DECK 2	HIGH speed	R53	6000 ~ 6020 Hz
	NORMAL speed	R54	3000 ~ 3010 Hz

- At first, adjust HIGH tape speed.
- Short TP51 on the MAIN PCB (Fig. 2-2) to get the HIGH tape speed.
(Short TP51 only after having started the tape to play at normal speed, and disconnect it before stopping the tape.)

- HIGH speed を先に調整すること。
- MAIN PCB 内の TP51 (Fig. 2-2) をショートすると、HIGH speed になります。
(TP51 は再生中にショートし、STOP する前にオープンすること。)

4. In play mode, check that the following value (speed drifting) are obtained at the beginning and the end of tape.

HIGH speed : within 90 Hz

NORMAL speed : within 45 Hz

2-1-3. Reel torque

1. Take-up torque/back tension torque:

The torque values when the test tape MTT-8111 for measuring torques is played back should be as follows:

Take-up torque (right reel) : 30 to 70 g.cm

Back tension torque (left reel) : 2 to 6 g.cm

2. FF/REW torque:

Load the test tape MTT-8242 for measuring torques, then measure the starting torque when the unit is in FF and REW operation. The standard values are as follows:

Torque in FF mode (right reel) : 90 to 180 g.cm

Torque in REW mode (left reel) : 90 to 180 g.cm

4. 巻き始めと巻き終わりを再生し、変動幅を確認する。

HIGH speed : 90 Hz 以内

NORMAL speed : 45 Hz 以内

2-1-3. リールトルク

1. テイクアップトルク／バックテンショントルク :

トルク測定用テストテープ MTT-8111 を再生したときのトルク値は下記の通りであること。

テイクアップトルク (右リール台) : 30 ~ 70 g.cm

バックテンショントルク (左リール台) : 2 ~ 6 g.cm

2. FF / REW トルク :

トルク測定用テストテープ MTT-8242 を装着し、FF 動作および REW 動作の起動トルクをそれぞれ測定する。規格値は次の通り。

FF トルク (右リール台) : 90 ~ 180 g.cm

REW トルク (左リール台) : 90 ~ 180 g.cm

2-2. ELECTRICAL ADJUSTMENT AND CHECKS

2-2-1. Precautions

1. Before performing adjustments and checks clean and demagnetize the entire tape path.
2. In general, adjustments and checks are made in the order of Lch then Rch. Double REF. Nos. indicate Lch /Rch. (Example ; R11/R21)
3. 0 dB is referenced to 0.775 V.
4. The AC voltmeter used in the procedures must have an input impedance of 1 M Ω or more.
5. Unless specified otherwise, adjustments and checks are made in FWD direction.

2-2-2. Adjustment and check locations

2-2. アンプ部の調整と確認

2-2-1. 注意

1. アンプ部の調整・確認の前に、テープ走行系の消磁と清掃を行ってください。
2. 特に指定のない限り、調整はLch、Rchの順序で行ってください。尚、R11/R21のように記されている回路番号はLch/Rchを示します。
3. 0 dB = 0.775 Vで表記しています。
4. 測定に使用するレベル計は、入力インピーダンス 1M Ω 以上のものとしてください。
5. 特に指定のない場合、調整および確認はFWD方向で行ってください。

2-2-2. 調整および測定箇所

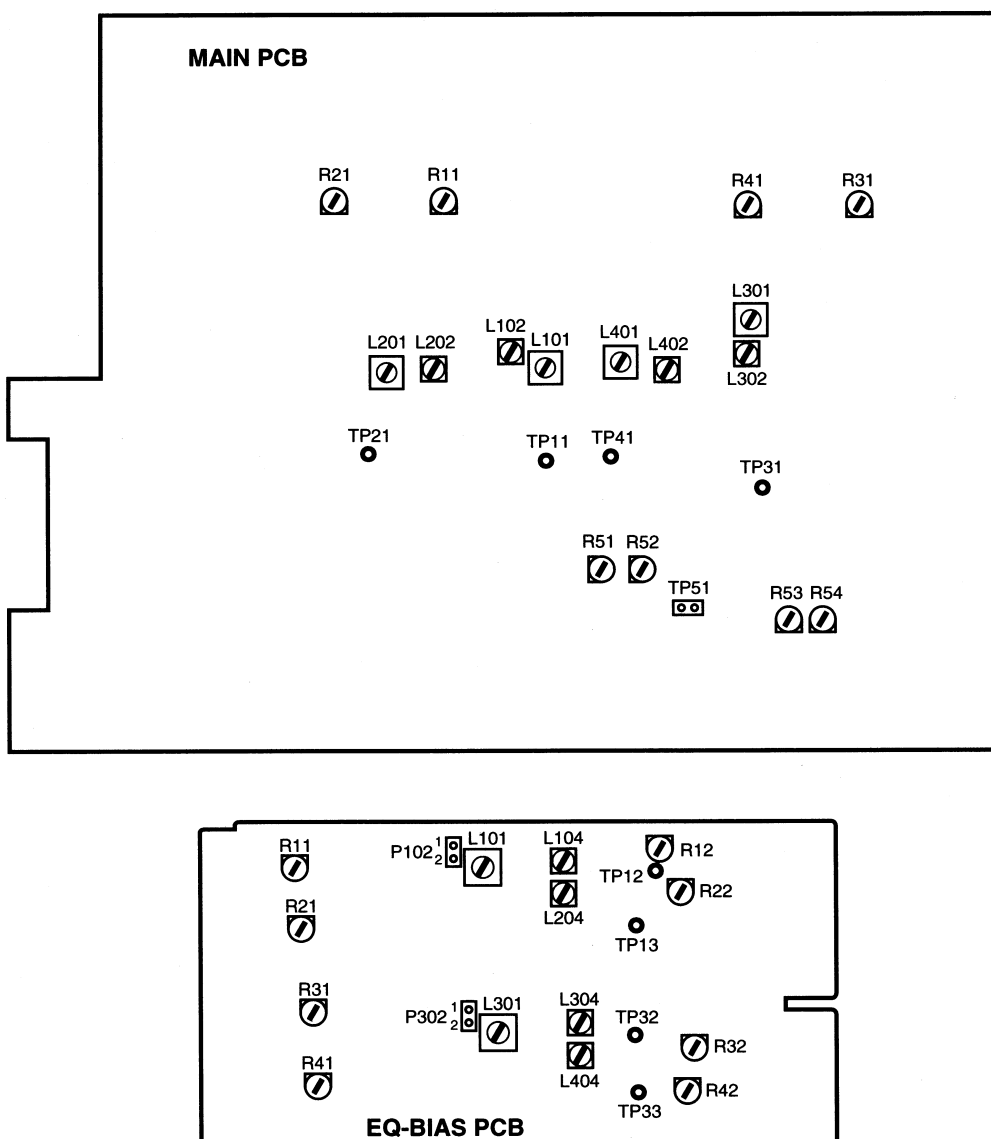

Fig. 2-2 Adjustment and check locations

2-2-3. Playback performance 再生系

Mode: PLAY

DOLBY NR switch: OFF

ITEM 項目	SETTING 設定	PLAYBACK SIGNAL 再生信号	ADJUSTMENT 調整	MEASUREMENT 測定	REMARKS 備考
1. REC/PLAY head azimuth 録/再ヘッド アジマス	Connection : Fig. 2-4	MTT-150	Check	LINE OUT : Phase: within 45°	Refer to Fig. 2-6
	Check/adjust in FWD, REV respectively FWD, REV それぞれ 実施	MTT-25702 (12.5 kHz)	Azimuth screws of R/P head (Fig.2-5) 録/再ヘッドのア ジマス調整ネジ	Max. output at L & Rch L & R 最大出力	
2. Specified output level 規定出力レベル	AC voltmeter connect- ed between TP terminal and GND. TP 端子と GND 間に AC 電圧計を接続	MTT-150	R11/R21 (MAIN PCB)	TP11/TP21 (MAIN PCB) : -6 dB (388 mV)	DECK 1
	FWD PLAY		R31/R41	TP31/TP41 : -6 dB (388 mV)	DECK 2
	FWD PLAY, REV PLAY	MTT-150	Check	LINE OUT : -3.5 dB \pm 1 dB (461 ~ 581 mV)	
3. Meter level メーターレベル		MTT-150	Check only	Level meter : 0 dB \pm 1 dB	
4. PHONES output level PHONES 出力	Connection : Fig. 2-7 PHONES control : Max.	MTT-150	Check only	PHONES OUT : -19 dB \pm 3 dB (61.5 ~ 123 mV)	8 Ω load
5. Playback frequency response 再生周波数特性	Connection : Fig. 2-3	MTT-25702	Check only	Fig. 2-8	
6. Playback SN ratio 再生 SN 比	Connection : Fig. 2-3	Leader tape with 70 μ (METAL) type case メタルテープのリーダー 一部を再生	Check only	47 dB min.	Rtio of ref. level to noise level 規定出力レベルと の比

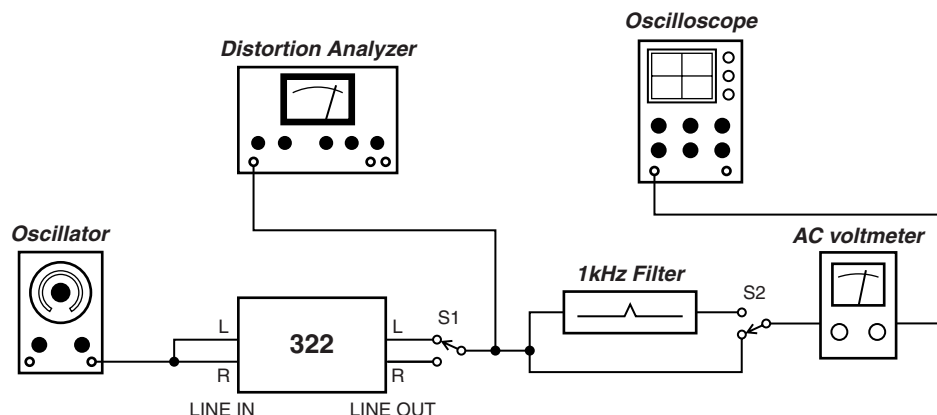

Fig. 2-3 Basic test setup

2-2-4. Monitor performance モニター系

Mode: REC PAUSE
 Signal input: LINE IN
 DOLBY NR switch: OFF

ITEM 項目	SETTING 設定	INPUT SIGNAL 入力信号	ADJUSTMENT 調整	MEASUREMENT 測定	REMARKS 備考
7. Min. LINE input level 最小ライン入力レベル	Connection : Fig. 2-3 INPUT control : MAX. REC BAL control : Center	400 Hz/-19 dB (87 mV)	Check only	LINE OUT : -3.5 dB ± 3 dB (367 ~ 731 mV)	
8. Specified LINE input level 規定ライン入力レベル	Connection : Fig. 2-3 REC BAL control : Center	400 Hz/-9 dB (275 mV)	INPUT control	LINE OUT : -3.5 dB (518 mV)	After adjusting, do not move (Specific position) 調整後はINPUT control を動かさないこと (規定位置)
9. Monitor SN ratio モニターSN比	Connection : Fig. 2-3	No signal 無信号	Check only	60 dB min.	Ratio of ref. level to noise level 規定出力レベルとの比

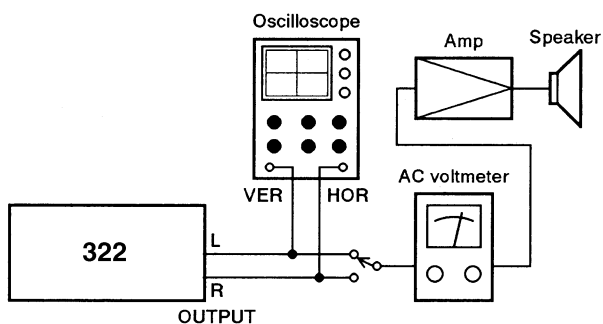

Fig. 2-4 Test setup for azimuth check

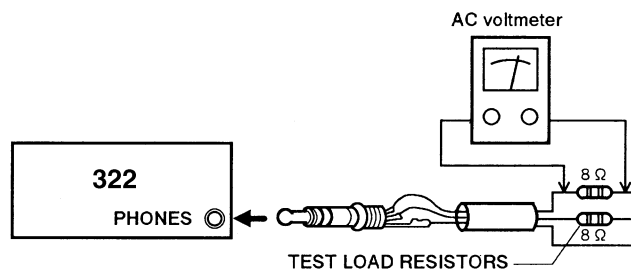

Fig. 2-7 Test setup for PHONES check

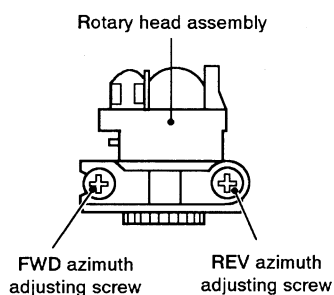

Fig. 2-5 Azimuth screw location

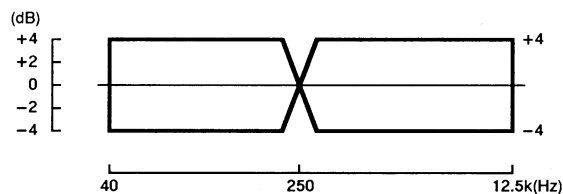

Fig. 2-8 Playback frequency response

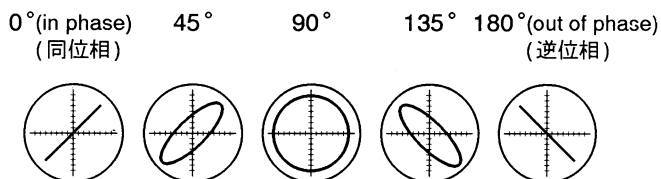

Fig. 2-6 Confirming phase relationship

2-2-5. Recording performance 録音系

Mode: REC/PLAY (unless otherwise specified 特に指示のある場合を除く)

Signal input: LINE IN

Measurement point: LINE OUT (unless otherwise specified 特に指示のある場合を除く)

DOLBY NR switch: OFF (unless otherwise specified 特に指示のある場合を除く)

INPUT control: Specified position 規定位置 (item 8)

REC BAL control: Center position センター位置

MTT-5513 : for NORMAL

MTT-5563 : for CrO₂

MTT-5572 : for METAL

ITEM 項目	SETTING 設定	INPUT SIGNAL 入力信号	ADJUSTMENT 調整	MEASUREMENT 測定		REMARKS 備考
10. Bias OSC バイアス発振器	Connection : Fig. 2-9 Tape : MTT-5513 Mode : REC	No signal 無信号	L101 (EQ-BIAS PCB)	P102-2 (EQ-BIAS PCB) : 100 KHz	DECK 1	
			L301	P302-2 : 100 KHz	DECK 2	
11. Step up coil ステップアップ コイル	DC voltmeter connected between TP terminal and GND. TP端子とGND間に DC電圧計を接続 Tape : MTT-5513 Mode : REC	No signal 無信号	L104/L204 (EQ-BIAS PCB)	TP12/TP13 (EQ-BIAS PCB) : Min. DC voltage DC電圧最小	DECK 1	
			L304/L404	TP32/TP33 : Min. DC voltage DC電圧最小	DECK 2	
12. Record bias 録音バイアス	Connection : Fig. 2-3 Tape : MTT-5513	250 Hz/-34 dB, 10 kHz/-34 dB (15.5 mV)	R12/R22 (EQ-BIAS PCB)	Nearly equal level at both frequencies 両周波数の出力レベル がほぼ等しくなるよう に調整	DECK 1	
			R32/R42		DECK 2	
13. MPX filter MPXフィルター	Connection : Fig. 2-3 DOLBY NR switch : B or C Mode : REC	19 kHz \pm 10 Hz/ -12 dB (195 mV)	L101/L201 (MAIN PCB)	30 dB min.	DECK 1	Ratio of ref. level to signal 規定出力レベルと の比
			L301/L401		DECK 2	
14. Record level adjustment 録音レベル調整	Connection : Fig. 2-3 Tape : MTT-5513	400 Hz/-12 dB (195 mV)	R11/R21 (EQ-BIAS PCB)	-6.5 dB (367 mV)	DECK 1	
			R31/R41		DECK 2	
15. Record level check 録音レベル確認	Connection : Fig. 2-3 Tape : MTT-5563 Tape : MTT-5572	400 Hz/-12 dB (195 mV)	Check only	-6.5 dB \pm 1 dB (327 ~ 411 mV)		
16. Total harmonic distortion 総合歪率	Connection : Fig. 2-3 Tape : MTT-5513 Tape : MTT-5563 Tape : MTT-5572	400 Hz/-9 dB (275 mV)	Check only	2.5 % or less		
17. Overall frequency response 総合周波数特性	Connection : Fig. 2-3 Tape : MTT-5513 Tape : MTT-5563 Tape : MTT-5572	40 Hz ~ 12.5 kHz/ -34 dB (15.5 mV)	Check only	Fig. 2-10		
18. Overall SN ratio 総合SN比	Connection : Fig. 2-3 Tape : MTT-5513 Tape : MTT-5563 Tape : MTT-5572	No signal 無信号	Check only	NORMAL : 44 dB min. CrO ₂ : 45 dB min. METAL : 46 dB min.	Ratio of ref. level to noise level 規定出力レベルと の比	

ITEM 項目	SETTING 設定	INPUT SIGNAL 入力信号	ADJUSTMENT 調整	MEASUREMENT 測定	REMARKS 備考
19. Erase efficiency 消去率	Connection : Fig. 2-3 (1 kHz B.P.F. in) Tape : MTT-5572	1 kHz/+1 dB (870 mV)	Check only	65 dB min.	
			Find the difference between the 1 kHz recorded portion and the erased portion. 1 kHz 録音部分とそれを消去した部分との出力レベルの比		
20. REC MUTE function REC MUTE 効果	Connection : Fig. 2-3 (1 kHz B.P.F. in) Tape : MTT-5572	1 kHz/+1 dB (870 mV)	Check only	55 dB min.	
			Find the difference between the 1 kHz recorded portion and the "REC MUTE" portion. 1 kHz 録音部分と REC MUTE 部分との出力レベルの比		
21. Channel separation チャンネルセパレーション	Connection : Fig. 2-3 (1 kHz B.P.F. in) Tape : MTT-5563	L ch : 1 kHz/-9 dB (275 mV) R ch : No signal	Check only	30 dB min.	
			Find the difference between the 1 kHz recorded portion (L ch) and the no signal portion (R ch). 1 kHz 録音部分 (Lch) と無信号録音部分 (Rch) との出力レベルの比		
22. Adjacent track crosstalk トラック間クロストーク	Connection : Fig. 2-3 Tape : MTT-5513	L ch : No signal R ch : 125 Hz/-9 dB (275 mV)	Check only	30 dB min.	
			Invert tape and play R ch track. Check leakage level against the output reference of previously recorded portion. 125Hz 録音部分 (Rch) の再生出力レベルを基準レベルとし、テープを反転して再生したときの Rch 出力レベルとの比		
14. Bias leakage バイアス漏れ	Connection : Fig. 2-3 Tape : MTT-5513 Mode : REC	No signal 無信号	L102/L202 (MAIN PCB) ----- L302/L402	-40 dB or less (7.75 mV)	DECK 1 ----- DECK 2

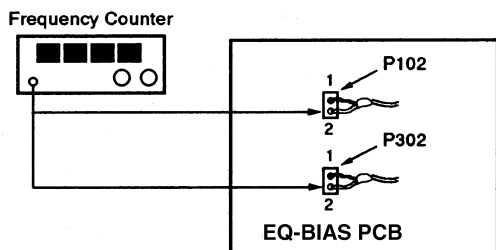

Fig. 2-9 Test setup for bias OSC adjustment

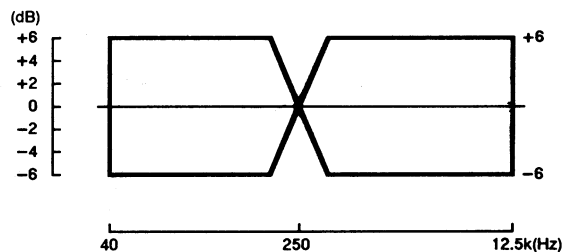
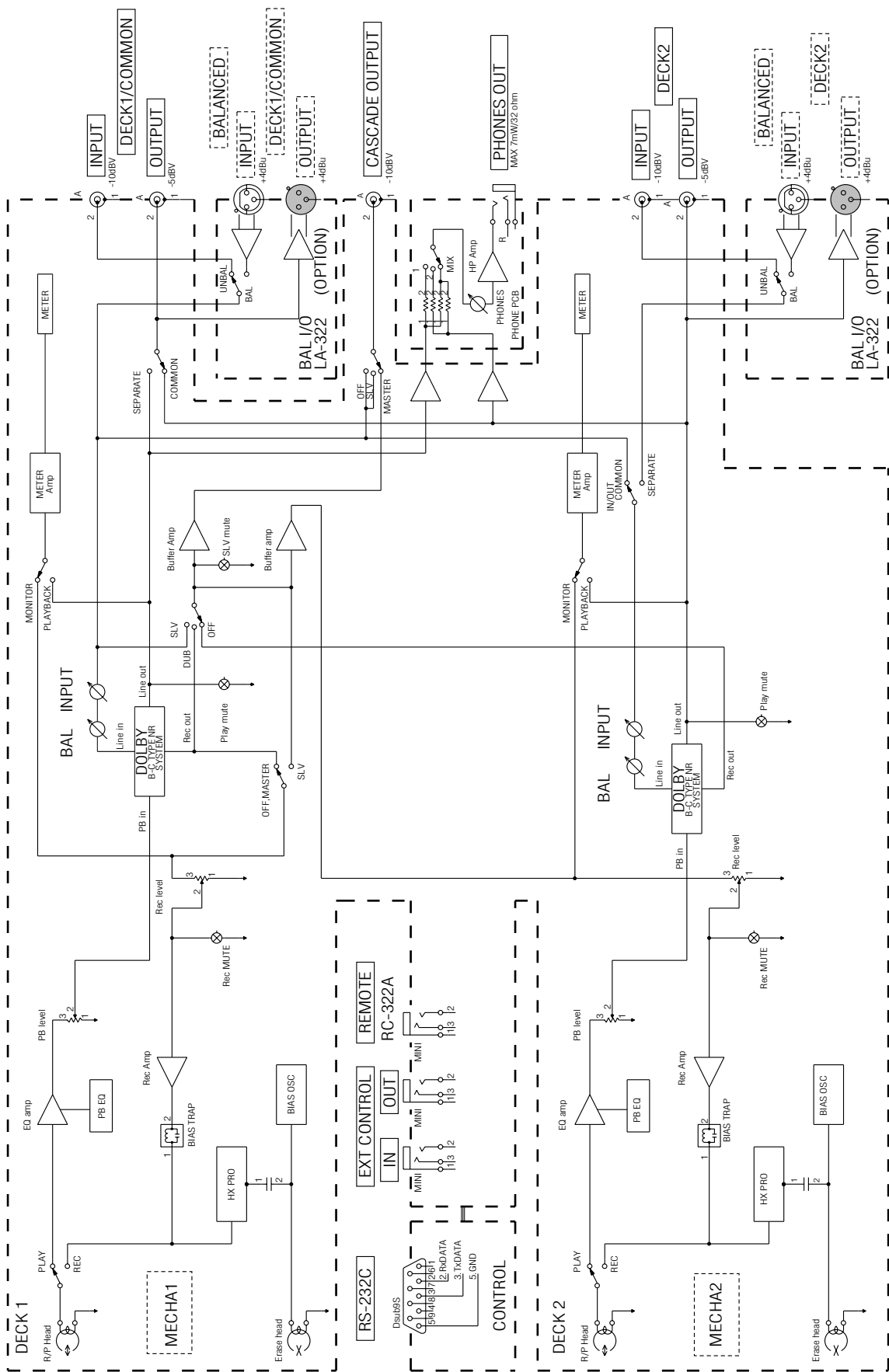

Fig. 2-10 Overall frequency response

3. BLOCK DIAGRAM

ブロックダイアグラム



PARTS LIST SECTION

NOTES

- PC boards shown are viewed from parts side.
- Parts marked with * require longer delivery time.
- The parts with no reference number or no parts number in the exploded views are not supplied.
- As regards the resistors and capacitors, refer to the circuit diagrams contained in the manual.
- △ Parts marked with this sign are safety critical components. They must be replaced with identical components - refer to the appropriate parts list and ensure exact replacement.
- Parts of [] mark can be used only with the version designated.
[J]: JAPAN [K]: KOREA [A]: AUSTRALIA [E]: EUROPE
[UK]: U.K. [US/C/GE]: U.S.A./CANADA/GENERAL EXPORTEXPORT

注意

- プリント基板は部品面が示されています。
- *印の部品は納期が若干かかります。
あらかじめご了承ください。
- 分解図に部番のない部品及び品番のない部品は供給しません。
- 標準の抵抗、コンデンサーは省略してあります。
回路図を参照してください。
- △は安全重要部品です。
交換する時は必ずティアック指定の部品を使用してください。
- 仕向先
[J]: JAPAN [K]: KOREA [A]: AUSTRALIA [E]: EUROPE
[UK]: U.K. [US/C/GE]: U.S.A./CANADA/GENERAL EXPORT

4. EXPLODED VIEWS AND PARTS LIST

分解図とパーツリスト

EXPLODED VIEW-1

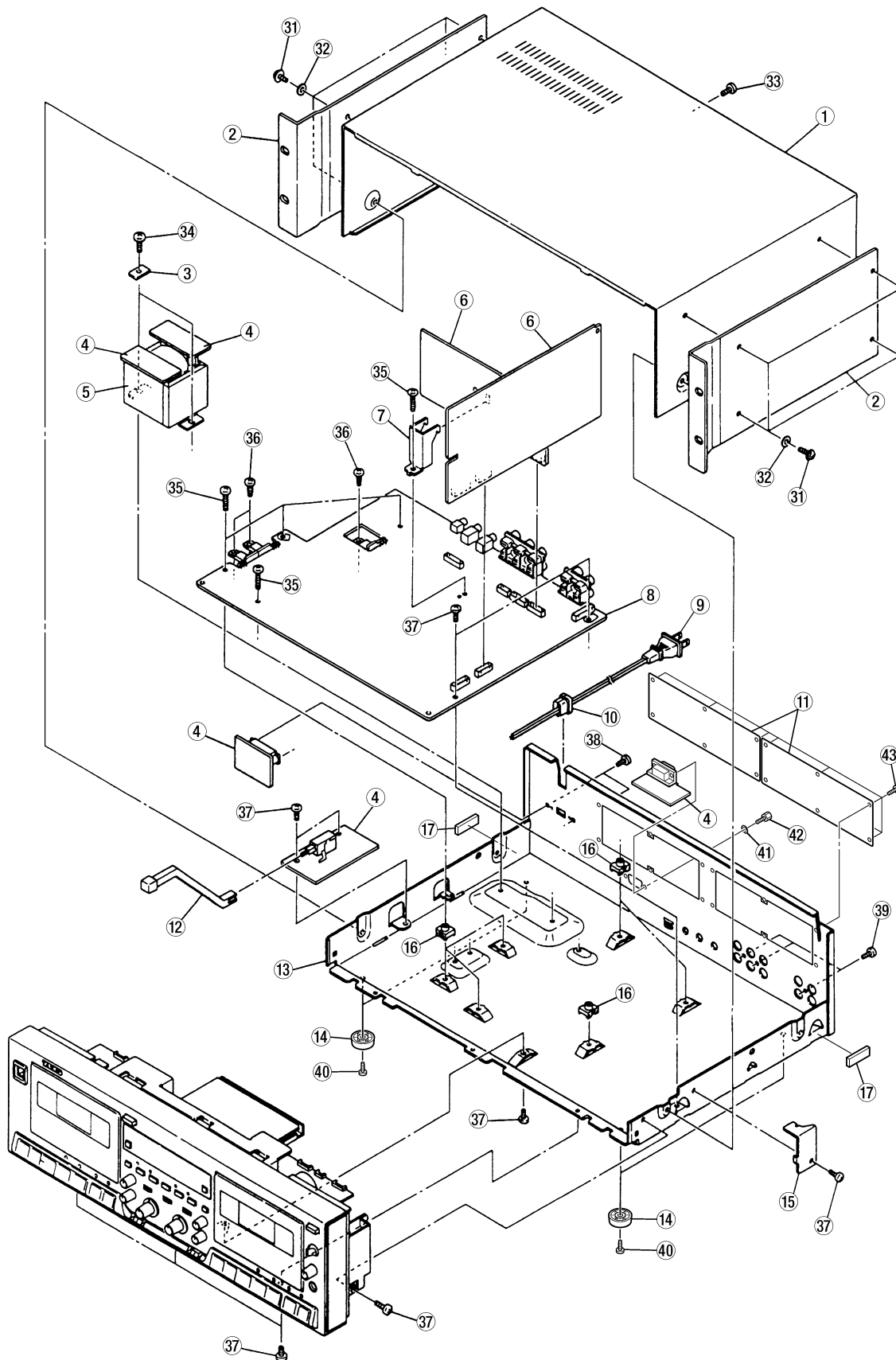

EXPLODED VIEW-1

REF. NO.	PARTS NO.	DESCRIPTION	REMARKS
1- 1	9260259100	BONNET	
1- 2	*9260293700	RACK MOUNTING	
1- 3	*9260158500	TR BRACKRT	
1- 4	*9145356000	GATHER PCB C ASSY [J,K,A,UK]	
	*9145356050	GATHER PCB C ASSY [E]	
	*9145356093	GATHER PCB C ASSY [US/C/GE]	
1- 5	△ 9125145500	POWER TRANSFORMER, PZ-J2046	
1- 6	*9145355000	GATHER PCB B ASSY	
1- 7	*9260234300	PCB BRACKET A	
1- 8	*9145354001	GATHER PCB A ASSY [J,US/C/GE]	
	*9145354050	GATHER PCB A ASSY [K,A,E,UK]	
1- 9	△ *E00423900A	AC CORD, 3A 250V [K]	
	△ *9109026010	AC CORD [A]	
	△ *9109026112	AC CORD [J]	
	△ *9109025711	AC CORD [E]	
	△ *9109027701	AC CORD WLTH FUSE [UK]	
	△ *9109029000	AC CORD [US/C/GE]	
1-10	△ *9121000102	BUSHING, #2271	
1-11	*9260349400	SUB REAR PANEL	
1-12	*9260231901	POWER BUTTON	
1-13	*9260349300	MAIN CHASSIS [J,K,A,E,UK]	
	*9260365400	MAIN CHASSIS [US/C/GE]	
1-14	*9260127100	FOOT 210	
1-15	*9260163900	PCB BRACKET	
1-16	*9260151300	PCB SUPPORT	
1-17	*9260241000	RUBBER (A)	
1-31	*9783053012	SCREW, CAP-S M3X12 (BLK)	
1-32	*9294209300	NYLON WASHER	
1-33	*9783593008	SCREW, C-TITE M3X8 (NI-BLK)	
1-34	*9783294010	SCREW, BTT-SSB M4X10	
1-35	*9783203014	SCREW, BTT-S M3X14	
1-36	*9783213008	SCREW BTT-B M3X8	
1-37	*9783203006	SCREW, BTT-S M3X6	
1-38	*9783233006	SCREW, BTT-S M3X6 (BLK) [US/C/GE]	
1-39	*9783613008	SCREW, BTT-P M3X8 (BLK)	
1-40	*9783103006	SCREW, CAP-S M3X6	
1-41	*9260330600	D-SUB WASHER, HW-C050MN00	
1-42	*9260330800	D-SUB SCREW, HW-H118EN00	
1-43	*9783243006	SCREW, BTT-B M3X6 (BLK)	

EXPLODED VIEW-2

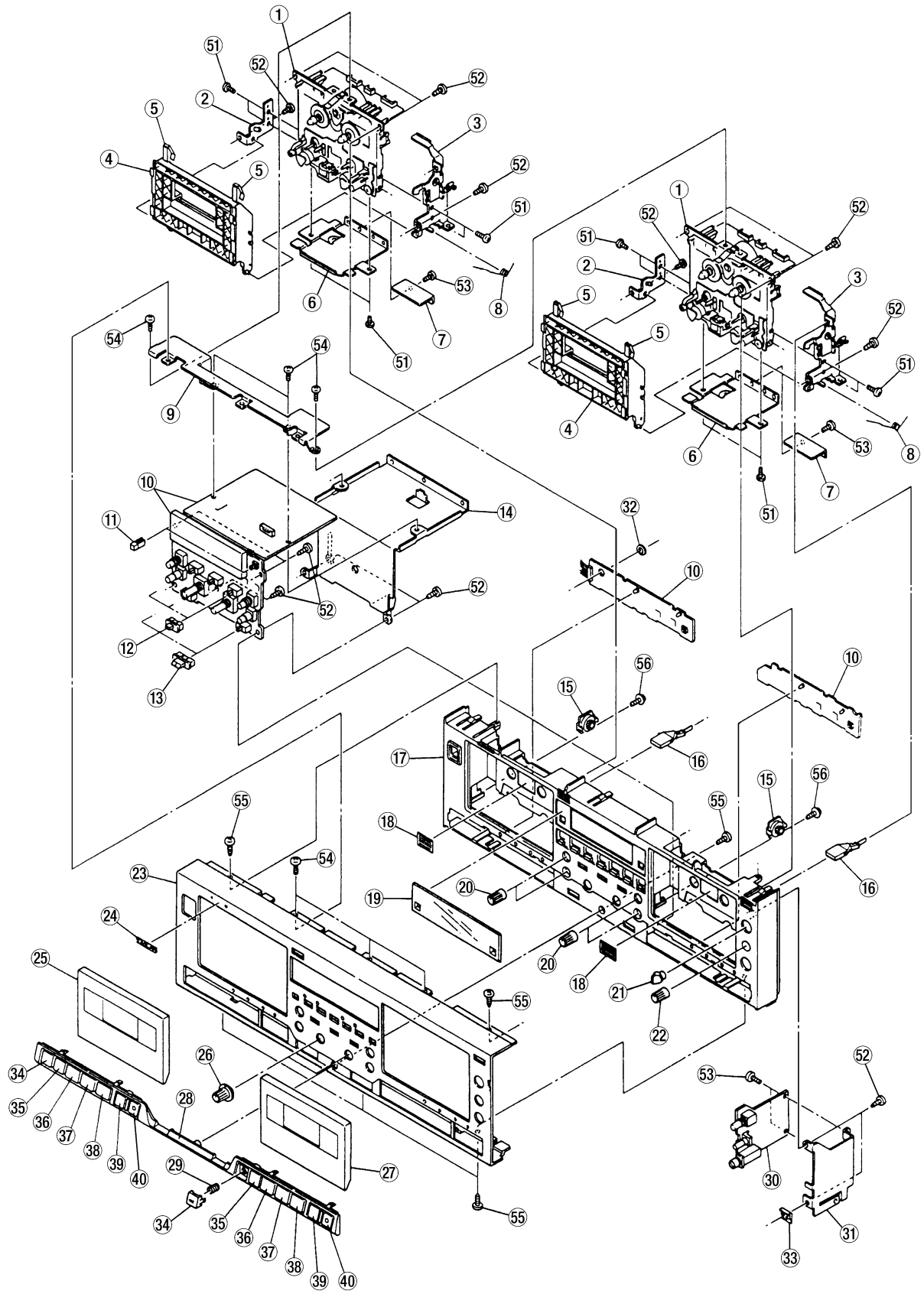

EXPLODED VIEW-2

REF. NO.	PARTS NO.	DESCRIPTION	REMARKS
2- 1	* 9278364101	MECH ASSY, CMAY2Z482B	
2- 2	* 9260163100	MECH BRACKET (L)	
2- 3	* 9260162604	MECH BRACKET (R) ASSY	
2- 4	9260255600	HAFT HOLDER ASSY	
2- 5	* 5800603801	HALF HOLDER SPRING	
2- 6	* 9260162501	SHIELD PLATE (HEAD)	
2- 7	* 9260168500	HEAD H. S PLATE	
2- 8	9260162801	CASE SPRING	
2- 9	* 9260230100	MECHA BRIGE	
2-10	* 9145356000	GATHER PCB C ASSY [J, K, A, UK]	
	* 9145356050	GATHER PCB C ASSY [E]	
	* 9145356093	GATHER PCB C ASSY [US/C/GE]	
2-11	* 9260231300	RESET BUTTON	
2-12	9260222400	SLIDE KNOB	
2-13	9260231601	SLIDE KNOB B	
2-14	9260230001	CENTER BRACKET	
2-15	* 9260173300	DAMPER	
2-16	* 9260230200	EJECT BUTTON	
2-17	* 9260234504	ESCUTCHEON SUB ASSY	
2-18	* 9260205700	PLATE, REFLECT	
2-19	9260231403	FL WINDOW	
2-20	9260230901	KNOB B	
2-21	9260231100	ROTARY SW KNOB	
2-22	9260231000	KNOB C	
2-23	* 9260349200	PANEL FRONT	
2-24	* 9260271101	BADGE TASCAM SILVER	
2-25	9260234601	CASSETTE LID ASSY A	
2-26	9260230801	KNOB A	
2-27	9260234701	CASSETTE LID ASSY B	
2-28	9260229805	MOLE	
2-29	* 9260231200	KEY SPRING	
2-30	* 9145355000	GATHER PCB B ASSY	
2-31	* 9260230400	PHONE BRACKET	
2-32	* 9260259301	NYLON SPACER	
2-33	* 9260234200	PCB SPACER B	
2-34	9260233503	REW KEY	
2-35	9260233403	FF KEY	
2-36	9260233603	STOP KEY	
2-37	9260233703	PLAY 1 KEY	
2-38	9260233803	PLAY 2 KEY	
2-39	9260233903	PAUSE KEY	
2-40	9260234003	REC KEY	
2-51	* 9783202604	SCREW, BTT-S M2. 6X4	
2-52	* 9783613008	SCREW, BTT-P M3X8 (BLK)	
2-53	* 9783203006	SCREW, BTT-S M3X6	
2-54	* 9783202606	SCREW, BTT-S M2. 6X6	
2-55	* 9783613008	SCREW, BTT-P M3x8 (BLK)	
2-56	* 9783402608	SCREW, CPA-P M2. 6X8	

EXPLODED VIEW-3

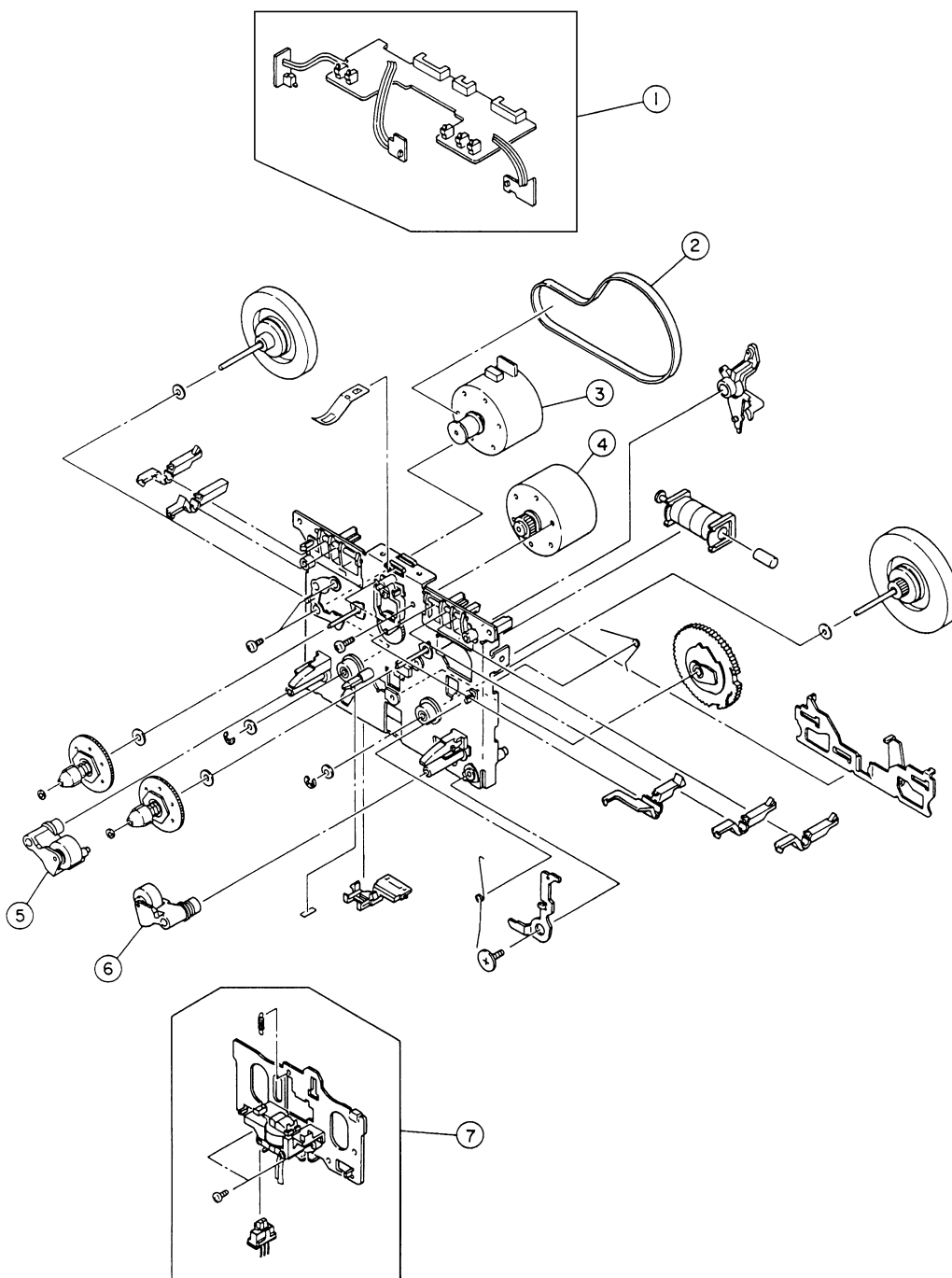

EXPLODED VIEW-3

REF. NO.	PARTS NO.	DESCRIPTION	REMARKS
3- 1	5761793800	PCB CONTROL BLK	
3- 2	5761790900	MAIN BELT	
3- 3	5761793700	MOTOR MAIN BLK	
3- 4	5761792300	MOTOR REEL BLK	
3- 5	5761791600	PINCH ROLLER ASSY, L	
3- 6	5761791500	PINCH ROLLER ASSY, R	
3- 7	5761794100	PLATE HD BLK	

5. PC BOARDS AND PARTS LIST

分解図とパーツリスト

GATHER PCB A ASSY

REF. NO.	PARTS NO.	DESCRIPTION
	*9145354001	GATHER PCB A ASSY [J, US/C/GE]
	*9145354050	GATHER PCB A ASSY [K, A, E, UK] MAIN PCB TR1 PCB TR2 PCB TR3 PCB
C503	△ 9117201020	C, ELEC 100UF/50V
C506	△ 9117228000	C, ELEC 330UF/16V
C507	△ 9117081021	C, ELEC 2.2UF/50V TP
C508, C512	△ 9117139021	C, ELEC 10UF/25V TP
C509, C510	△ 9117302200	C, ELEC 4700UF/16V
C511	△ 9117303600	C, ELEC 4700UF 25V
C516	△ 9117302200	C, ELEC 4700UF/16V
C530	△ 9117303400	C, ELEC 1000UF/16V
D103-105	9165022150	DIODE, TP 1SS133T
D106	9165020550	DIODE, LT 1N4003 TP 0.6MM
D107	9165022150	DIODE, TP 1SS133T
D301, 302	9165022150	DIODE, TP 1SS133T
D307	9165022150	DIODE, TP 1SS133T
D501	△ 9165022150	DIODE, TP 1SS133T
D502	△ 9166030652	Z-DIODE, MTZJ20C
D503, 513	△ 9165020550	DIODE, LT 1N4003 TP 0.6MM
D504, 514	△ 9165020560	DIODE, 1N4003 TP
D505, 506	△ 9165020560	DIODE, 1N4003 TP
D507-512	△ 9165020550	DIODE, LT 1N4003 TP 0.6MM
D515	9166036051	Z-DIODE, RD4.7E B2 TP
D516	9166052751	Z-DIODE, MTZ J2.7B
D517	9166030850	Z-DIODE, MTZ J 4.3B T72
D518	9165020550	DIODE, LT 1N4003 TP 0.6MM
D519	9166036051	Z-DIODE, RD4.7E B2 TP
D520, 523	9166036451	Z-DIODE, RD6.8E B2 TP
D521	9165020550	DIODE, LT 1N4003 TP 0.6MM
D522	9166036051	Z-DIODE, RD4.7E B2 TP
D524, 525	9166036051	Z-DIODE, RD4.7E B2 TP
FR1-3	△ 9114421000	FUSE, ERON 16NK 1/6W [K, A, E, UK]
J101	9143982000	RCA PIN JACK, 6P CPS-056
J102	9143188000	PIN JACK, 4P (YKC21-0066B)
J501	9143984000	MINIATURE JACK, YKB21-5229
J502, 503	9144176000	MINIATURE JACK, CPJ-3055
K101	9138001600	RELAY, AHX203
L101, 201	9173007000	LOW PASS FILTER, MPX
L102, 202	9173009800	TRAP COIL, 100KHZ
L301, 401	9173007000	LOW PASS FILTER, MPX
L302, 402	9173009800	TRAP COIL, 100KHZ
P11	9143232000	PLUG, B4B-PH 4P
P12	9143172000	PLUG CONNECTOR, B4B-EH-A
P13	9143231000	PLUG, B3B-PH 3P
P14	9143171000	PLUG CONNECTOR, B3B-EH 3P
P15	9143231000	PLUG, B3B-PH 3P
P16	9143231020	CONNECTOR PLUG, 3P (RED)

GATHER PCB A ASSY

REF. NO.	PARTS NO.	DESCRIPTION
P101	9143235000	PLUG, B7B-PH 7P
P103	9143165000	PLUG, B11B-XH-A 11P
P104	9143161000	CONNECTOR PLUG, 7P
P105	9143162000	CONNECTOR PLUG, 8P B8B-XH-A
P107	9143164000	PLUG, 10P B10B-XH-A
P108	9143159000	PLUG, 5P B5B-XH-A
P109	9143162000	CONNECTOR PLUG, 8P B8B-XH-A
P110	9143161000	CONNECTOR PLUG, 7P
P301	9143235020	PLUG, 7P RED (B7B-PH-K)
P501	9143176000	PLUG 8P (B8B-EH-A)
P502	9143239000	PLUG, 11P B11B-PH-K
P503	9143236000	PLUG, B8B-PH 8P
P504	9143235000	PLUG, B7B-PH 7P
P505	9143232000	PLUG, B4B-PH 4P
P506	9143232020	CONNECTOR PLUG, 4P (RED)
P507	9143233040	PLUG, B5B-PH 5P (YEL)
P508	9143235020	PLUG, 7P RED (B7B-PH-K)
Q101, 201	9163609920	TR, 2SD-2144S
Q102, 202	9163609920	TR, 2SD-2144S
Q103, 104	9163011220	DTR, DTA 124ES TP
Q105	9163310420	DTR, DTC 124ES TP
Q106	9163011220	DTR, DTA 124ES TP
Q107	9163310420	DTR, DTC 124ES TP
Q108, 208	9163309420	TR, 2SC1815GR (TP)
Q109	9163310420	DTR, DTC 124ES TP
Q110	9163309420	TR, 2SC1815GR (TP)
Q112	9163310420	DTR, DTC 124ES TP
Q113, 313	9163011220	DTR, DTA 124ES TP
Q114, 214	9163309420	TR, 2SC1815GR (TP)
Q301, 401	9163609920	TR, 2SD-2144S
Q302, 402	9163609920	TR, 2SD-2144S
Q303, 304	9163011220	DTR, DTA 124ES TP
Q305	9163310420	DTR, DTC 124ES TP
Q306	9163011220	DTR, DTA 124ES TP
Q307	9163310420	DTR, DTC 124ES TP
Q312, 315	9163310420	DTR, DTC 124ES TP
Q501	△ 9163309420	TR, 2SC1815GR (TP)
Q502	△ 9163009920	TR, 2SA1015GR (TP)
Q503	9163011220	DTR, DTA 124ES TP
Q504	9163009920	TR, 2SA1015GR (TP)
Q505	△ 9163204700	TR, 2SB1134R
Q506, 507	9163011220	DTR, DTA 124ES TP
Q508	9163310420	DTR, DTC 124ES TP
Q509, 510	9163309820	TR, 2SC2120Y (TP)
Q511	9163310420	DTR, DTC 124ES TP
Q512, 513	9163309820	TR, 2SC2120Y (TP)
Q514-517	9163310420	DTR, DTC 124ES TP
R11, 21	9112057000	VR, SEMI-FIXED 22K (B)
R31, 41	9112057000	VR, SEMI-FIXED 22K (B)
R51, 53	9112065800	SEMI-FIXED, 10KBRH0681C14J
R52, 54	9112065900	SEMI-FIXED, 22KBRH0681CJ4J
R508	△ 9113050050	R, R-16 TP JFT 120
R513	△ 9113054050	R, R-16 TP JFT 180

GATHER PCB A ASSY

REF. NO.	PARTS NO.	DESCRIPTION
R536, 545	9114100110	R. METAL OXIDE, 1W 47J FH12
U101, 301	9167072600	IC, CXA1561S (22P)
U103, 303	9167072700	IC, CXA1598S (22P)
U104, 304	9167018900	IC, ANALOG BU4051B
U107	9167019800	IC, BU4052B
U108	9167029700	IC, NJM5532D
U109	9167019800	IC, BU4052B
U110	9167008100	IC, NJM4558D (8P)
U501	△ 9167025600	IC, NJM317F
U502	△ 9167021710	IC, NJM78M05FA (3P)
U503	9167028700	IC, CXA1511L (8P)
U504	9167028900	IC, TLP521-2 (GB)
U505, 506	9167028600	IC, NJU3714D
U507	9167019000	IC, DIGITAL BU4053B
U508, 509	9167021100	IC, BA6219B (10P)
U510	9167019000	IC, DIGITAL BU4053B

GATHER PCB B ASSY

REF. NO.	PARTS NO.	DESCRIPTION
	* 9145355000	GATHER PCB B ASSY EQ-BIAS PCB PHONE PCB ANLOG SW PCB
D101, 301	9166052951	Z-DIODE, MTZ J 3.3B T72
D801, 901	9165022150	DIODE, TP 1SS133T
D802, 902	9165022150	DIODE, TP 1SS133T
D803, 903	9165022150	DIODE, TP 1SS133T
D804, 904	9165022150	DIODE, TP 1SS133T
J61	9144059000	PHONE JACK, CPJ-065
L101	9173007200	OSC COIL, 100KHZ
L102, 103	9173006350	COIL, 220MH EC36-221K-T5
L104, 204	9173007700	STEP UP COIL
L105, 205	9122017600	BIAS TRAP COIL, 100KHZ
L301	9173007200	OSC COIL, 100KHZ
L302, 303	9173006350	COIL, 220MH EC36-221K-T5
L304, 404	9173007700	STEP UP COIL
L305, 405	9122017600	BIAS TRAP COIL, 100KHZ
P101	9143173000	CONNECTOR PLUG, 5P
P102	9143170000	CONNECTOR PLUG, 2P
P103	9140099011	PLUG, 11P 11JQ-ST
P104	9140099007	SOCKET, 7P 07JQ-ST
P105	9140099008	SOCKET, 8P 08JQ-ST
P301	9143173020	PLUG, 5P B5B-EH-K (RED)
P302	9143170020	PLUG, 2P B2B-EH-K (RED)
P801	9140099010	SOCKET, 10P 10JQ-ST
P802	9140099005	SOCKET, 5P 05JQ-ST
P803	9140099008	SOCKET, 8P 08JQ-ST
P804	9140099007	SOCKET, 7P 07JQ-ST
P805	9143235040	PLUG, 7P B7B-PH-K (YEL)

GATHER PCB B ASSY

REF. NO.	PARTS NO.	DESCRIPTION
P806	9143239000	PLUG, 11P B11B-PH-K
P808	9143230000	PLUG B2B-PH 2P
P809	9143230020	PLUG B2B-PH 2P (RED)
P810	9143231000	PLUG B3B-PH 3P
Q101, 301	9163311520	TR, 2SC2240 GR TP
Q102, 302	9163311520	TR, 2SC2240 GR TP
Q103, 303	9163309420	TR, 2SC1815GR (TP)
Q104, 304	9163310820	TR, DTC143TS T.P
Q105, 305	9163310820	TR, DTC143TS T.P
Q106, 306	9163310820	TR, DTC143TS T.P
Q107, 307	9163309420	TR, 2SC1815GR (TP)
Q108, 308	9163309420	TR, 2SC1815GR (TP)
Q109, 309	9163011220	DTR, DTA 124ES TP
Q110, 310	9163011220	DTR, DTA 124ES TP
Q111, 311	9163310420	DTR, DTC 124ES TP
Q112	9163011220	DTR, DTA 124ES TP
Q115, 315	9163011220	DTR, DTA 124ES TP
Q116, 316	9163011220	DTR, DTA 124ES TP
Q117, 317	9163310420	DTR, DTC 124ES TP
Q118, 318	9163310420	DTR, DTC 124ES TP
Q119, 319	9163309420	TR, 2SC1815GR (TP)
Q120, 320	9163309420	TR, 2SC1815GR (TP)
Q121, 321	9163011320	TR, TP 2SA933ALN-S
Q122, 322	9163310420	DTR, DTC 124ES TP
Q123, 323	9163309420	TR, 2SC1815GR (TP)
Q124, 324	9163310420	DTR, DTC 124ES TP
Q125, 325	9163310420	DTR, DTC 124ES TP
Q202, 402	9163311520	TR, 2SC2240 GR TP
Q203, 403	9163309420	TR, 2SC1815GR (TP)
Q204, 404	9163310820	TR, DTC143TS T.P
Q205, 405	9163310820	TR, DTC143TS T.P
Q206, 406	9163310820	TR, DTC143TS T.P
Q208, 408	9163309420	TR, 2SC1815GR (TP)
Q901	9163310420	DTR, DTC 124ES TP
R11, 21	9112060300	SEMI-FIXED VR, 100 (B)
R12, 22	9112062900	SEMI-FIXED VR, 4.7K (B)
R31, 41	9112060300	SEMI-FIXED VR, 100 (B)
R32, 42	9112062900	SEMI-FIXED VR, 4.7K (B)
R61	9172026000	VR, 50K (A) K091E0Z0B
S61	9135036500	ROTARY SW, 2-3 SRBM
U101, 301	9167014000	IC, UPC4570C
U102, 302	9167012800	IC, UPC1297CA (18P)
U601	9167014000	IC, UPC4570C
U801, 901	9167019800	IC, BU4052B
U802, 902	9167019800	IC, BU4052B
U803, 903	9167008100	IC, NJM4558D (8P)
U804, 904	9167008100	IC, NJM4558D (8P)
U805, 905	9167012400	IC, BA335

GATHER PCB C ASSY

REF. NO.	PARTS NO.	DESCRIPTION
	*9145356000	GATHER PCB C ASSY [J,K,A,UK]
	*9145356050	GATHER PCB C ASSY [E]
	*9145356093	GATHER PCB C ASSY [US/C/GE]
		FRONT PCB
		CONTROL PCB
		KEY 1 PCB
		KEY 2 PCB
		TRANS 1 PCB
		TRANS 2 PCB
		POWER SW PCB
		SW PCB
		RS-232C PCB
C701	△ 9120000101	SPARK KILLER, 0.0047M 250V
D1, 2	9165023220	DIODE, 1SS131 T-72
D500	9174015800	LED (RED), SLR-342VR-3F
D501	9174015900	LED (AMBER), SLR-342DU-3F-M
D502, 503	9174015800	LED (RED), SLR-342VR-3F
D500-503	9260211800	LED SPACER SUPPORTS
D600, 601	9174019300	LED, SLR-342MG-3F
D602	9174015900	LED (AMBER), SLR-342DU-3F-M
D603	9174015800	LED (RED), SLR-342VR-3F
D600-603	9260210000	LED SPACER, LEDS-2
D650	9174015800	LED (RED), SLR-342VR-3F
D651	9174015900	LED (AMBER), SLR-342DU-3F-M
D652, 653	9174019300	LED, SLR-342MG-3F
D650-653	9260210000	LED SPACER, LEDS-2
FL500	9174019400	FL DISPLAY, BJ-364GNK
FL500	9260230300	FL HOLDER
J1	9144484000	D-SUB, DE-09SLURL2
J702	9144177000	TERMINAL LAPPING 2P [E, US/C/GE]
L1, 2	9122020320	FILTER, EXC EMT102BT TP
P1	9143230000	PLUG, B2B-PH 2P
P500	9143237000	PLUG, 9P (B9B-PH-K)
P501	9143237020	PLUG, 9P (B9B-PH-K) RED
Q501-503	9163310420	DTR, DTC 124ES TP
RA522-524	9111284000	R, ARRAY 100KX8
R520, 521	9111279000	R, ARRAY 10KX6
R590, 595	9172025900	VR, 100K(W) K091FOG0A
R591, 596	9172026100	VR, 50K(A) RK14K12D0025-TK
R594, 599	9172026200	VR, 10K(B) RK11K114S206-TK
SW1	△ 9135032000	SW, SDDL1087U
S500, 504	9136002000	TACT SW, SKHHDA
S501-503	9136001820	TACT SW, SKHVBE3520-TK
S505-508	9136001820	TACT SW, SKHVBE3520-TK
S509	9135042700	SLIDE SW, SSSF023NA3-TK
S510	9134011100	SW SLIDE, SSSF013NA3-TK
S511	9135032401	BBE SW, SSSF012
S512, 513	9134011100	SW SLIDE, SSSF013NA3-TK
S600-606	9136001820	TACT SW, SKHVBE3520-TK
S650-656	9136001820	TACT SW, SKHVBE3520-TK
S702	△ 9134010700	SW, AC SELECTOR [US/C/GE]

GATHER PCB C ASSY

REF. NO.	PARTS NO.	DESCRIPTION
U1	9167035400	IC, NJU6402B
U500	9167028100	IC, BA10393N
U501	9167072800	MICON IC, CXP82032 (100P)
U502	9167028500	IC M51957BL
U503, U504	9167028100	IC, BA10393N
X500	9173021000	OSC, CSTLS16MOX51-B0

GATHER PCB A (MAIN PCB, TR1 PCB, TR2 PCB, TR3 PCB)

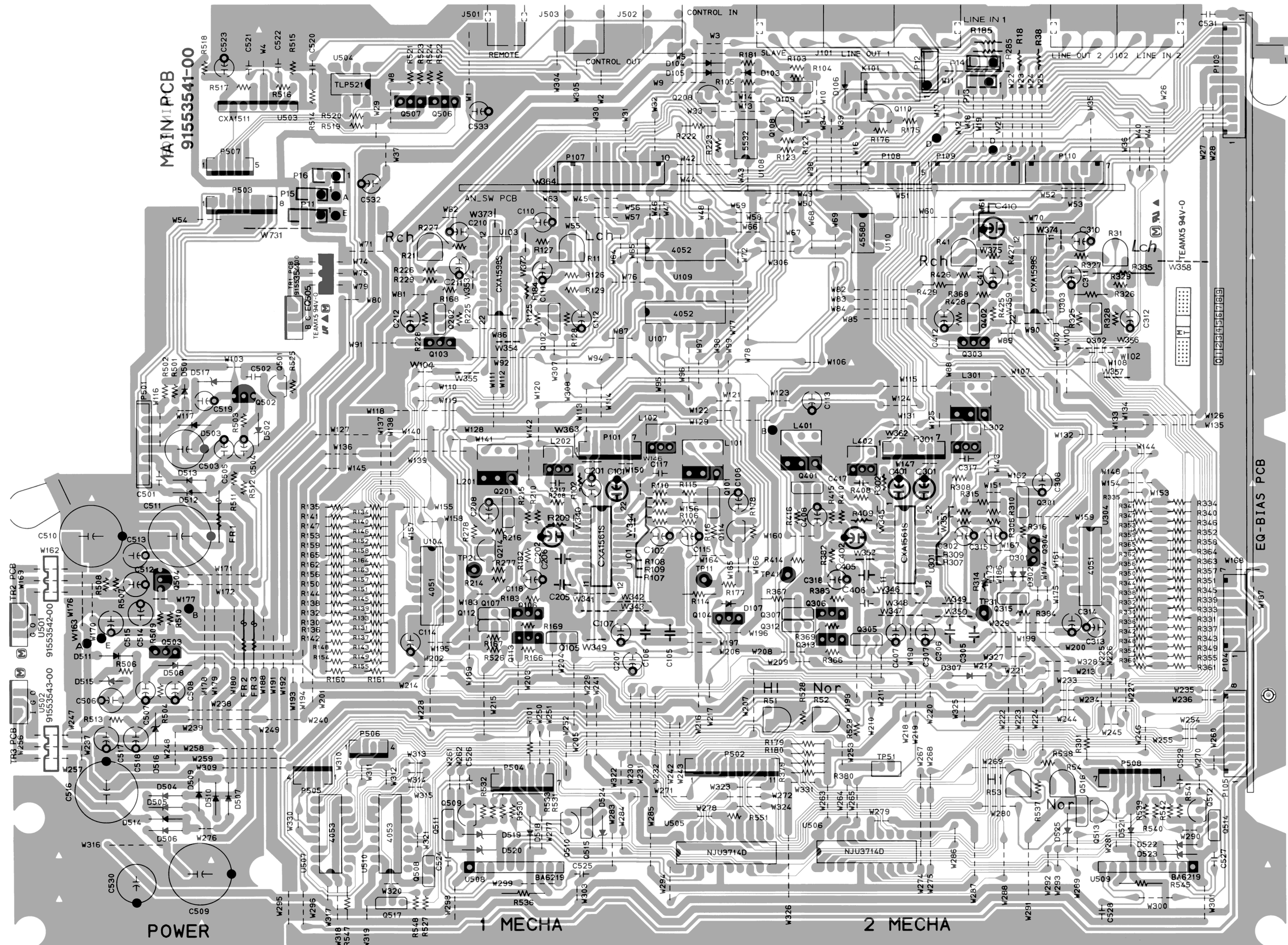

GATHER PCB B (EQ-BIAS PCB, ANALOG SW PCB, PHONE PCB)

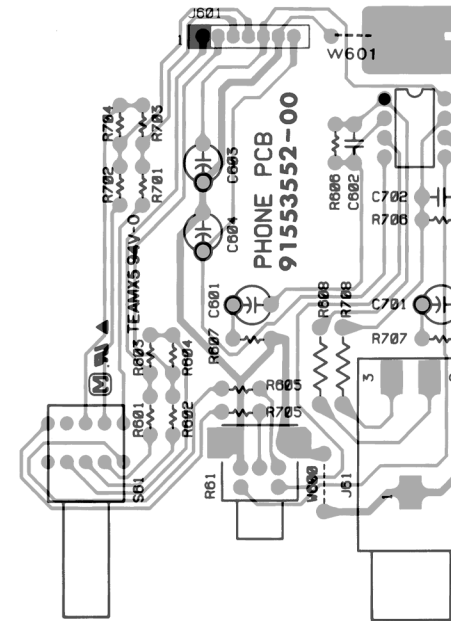
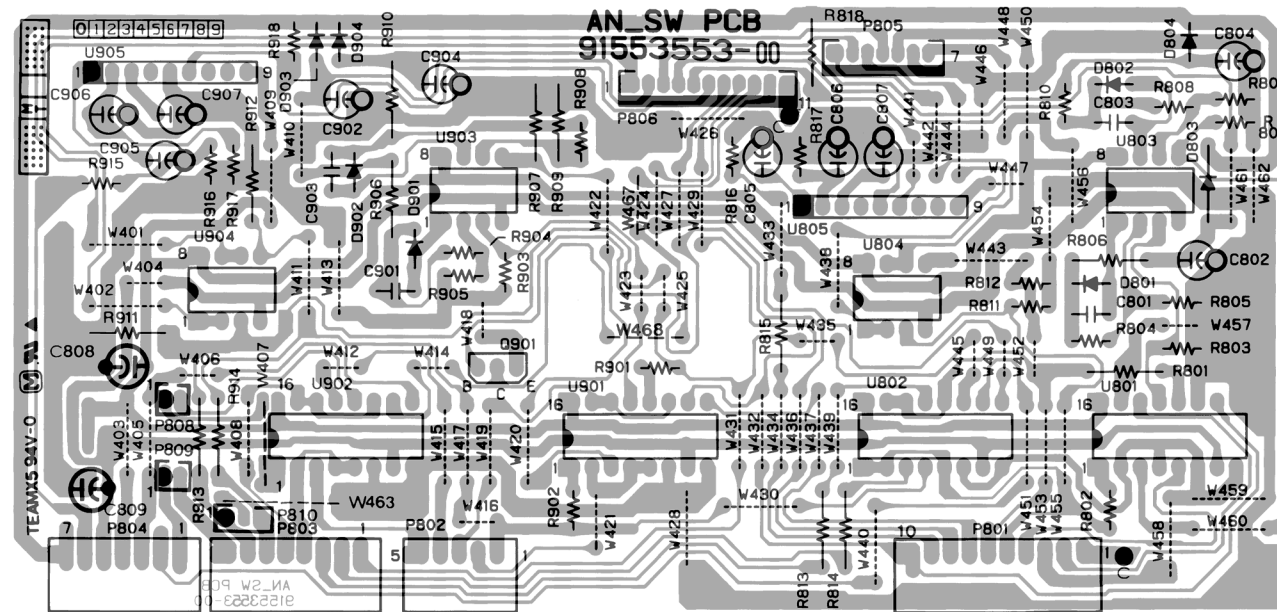
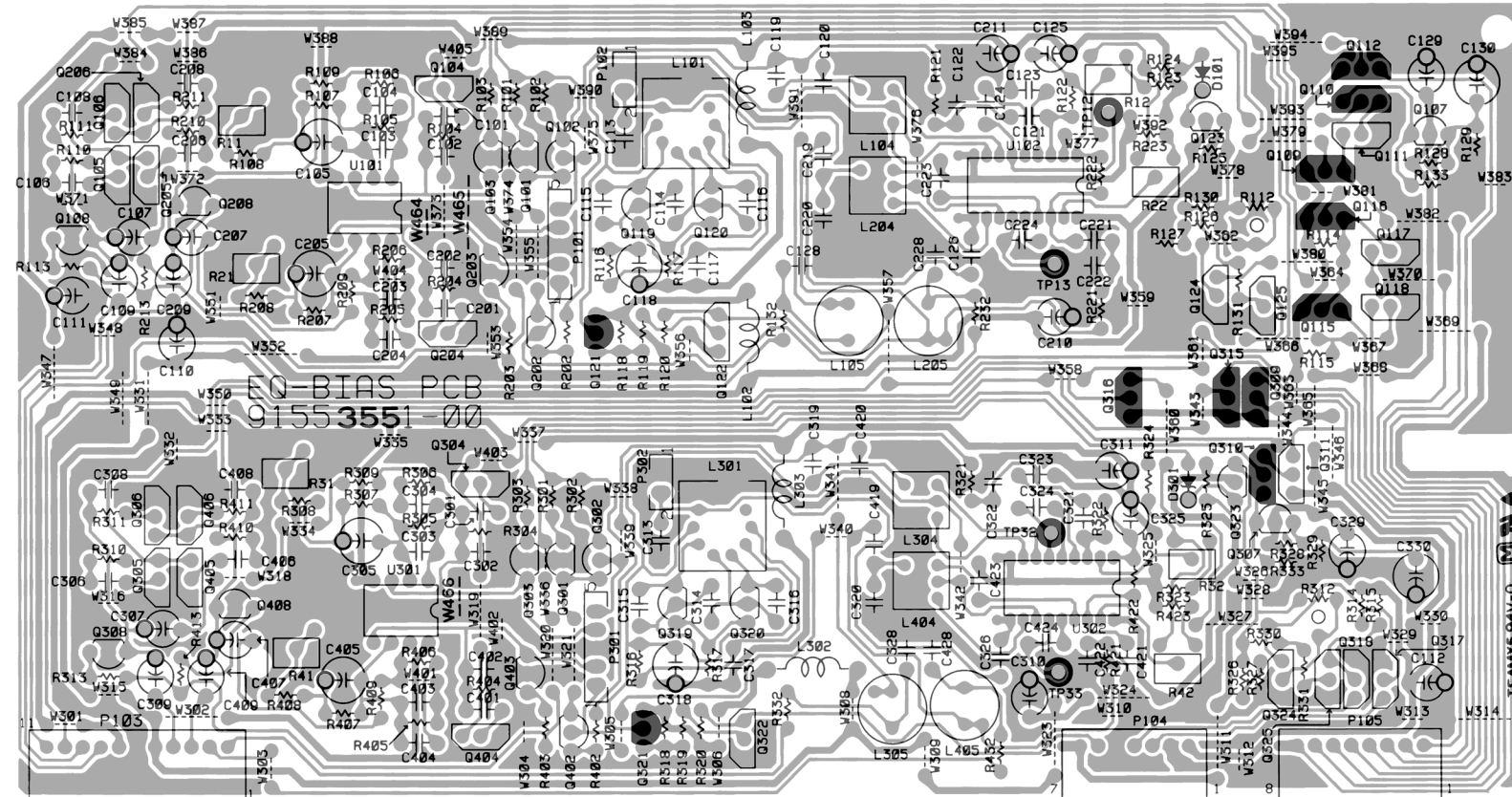

GATHER PCB C (FRONT PCB, CONTROL PCB, KEY 1/2 PCB, TRANS 1/2 PCB, POWER SW PCB, SW PCB, RS-232C PCB)

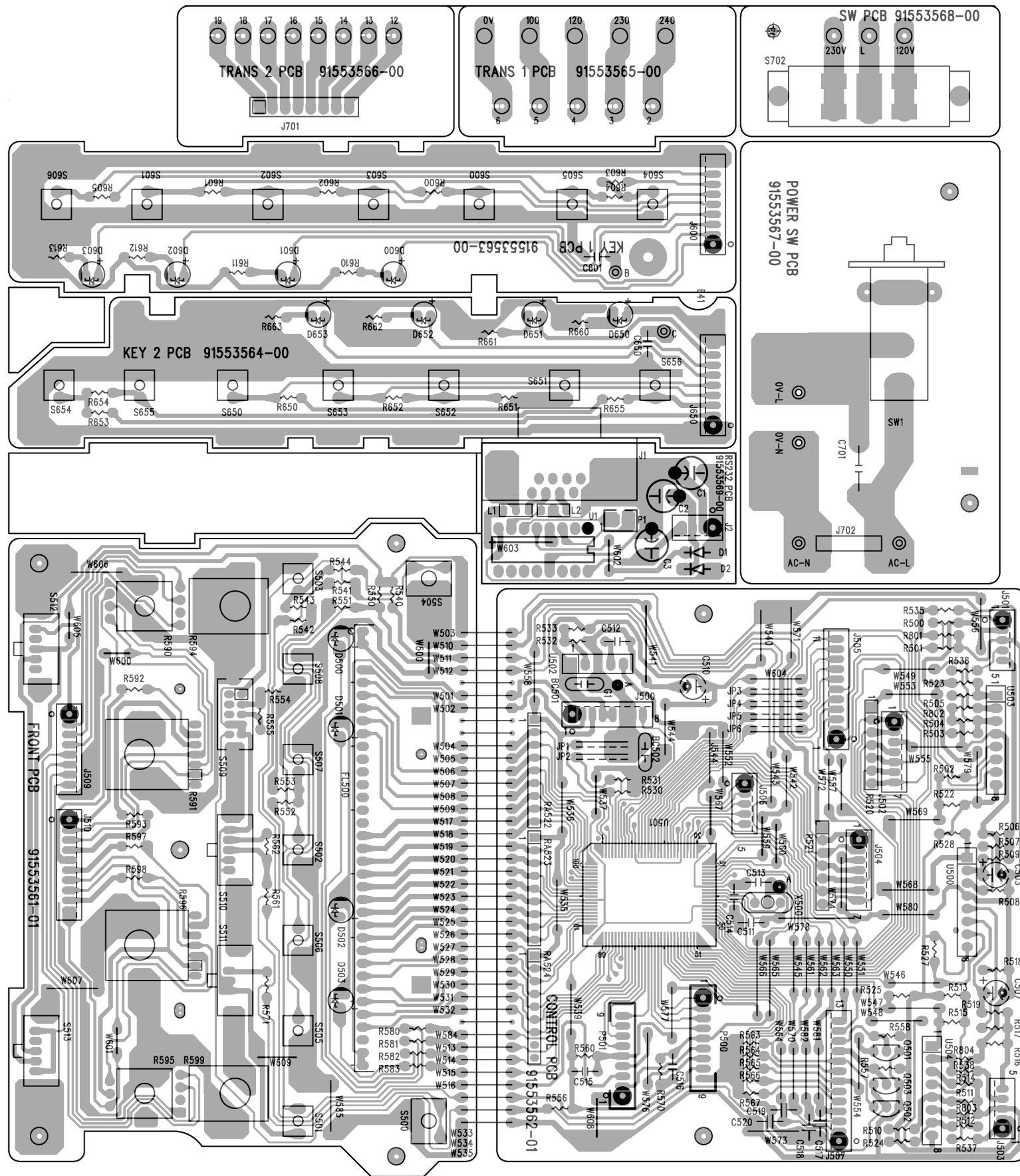

LA-322 (BAL AMP 1 PCB, BAL AMP 2 PCB)

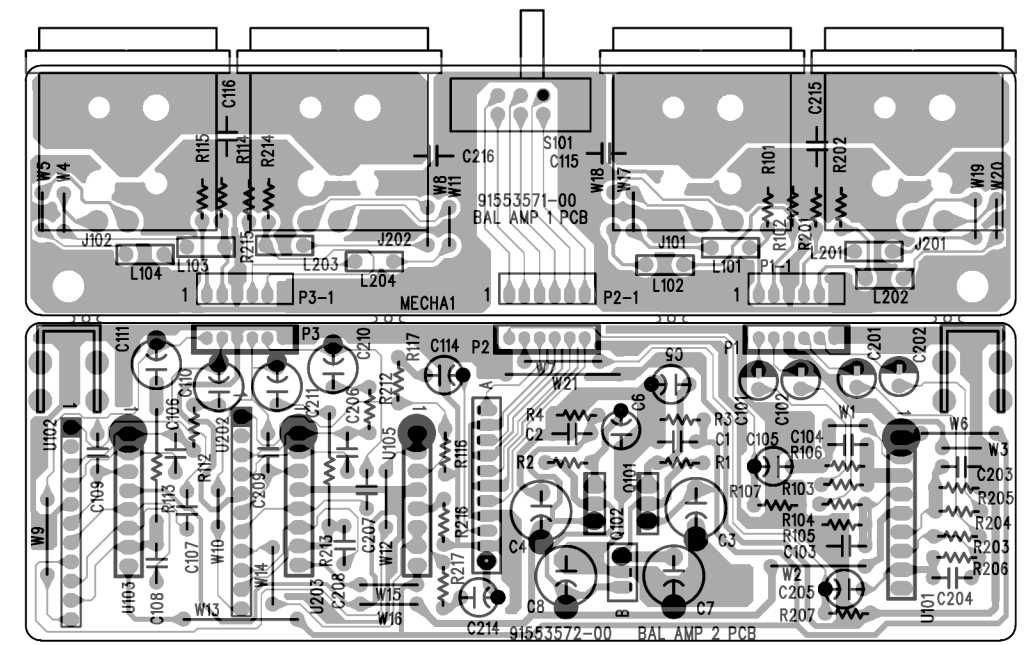

6. INCLUDED ACCESSORIES

付属品

INCLUDED ACCESSORIES

REF. NO.	PARTS NO.	DESCRIPTION	REMARKS
	* 9101439300	OWNER'S MANUAL (JPNANESE) [J]	
	* 9101439400	OWNER'S MANUAL (ENGLISH) [E, US/C/GE]	
	* 9151003800	REMOTE CONTRPL UNIT, RC-322A	
	* 9260221600	MOUNT SCREW KIT ASSY	